



Universal Remote Kit Installation

Congratulations on your purchase of a high quality PUTCO product. Should you need any application or technical assistance feel free to call us at: 1-800-357-3974
Monday-Friday 8:00 a.m. - 5:00 p.m. (Central Standard Time)
Contact your PUTCO dealer for other quality accessories.

Please read all instructions before installation and to check to see that all parts are included.

KIT CONTENTS:	
Description	Qty.
RF Control Module	1
Key Fob	1

Tools/Supplies:

- Screwdriver
- Double sided tape or Zip Ties

Universal Remote Installation

1. Remove Universal Remote Kit from packaging. Check to see if all parts from above table are included.
2. Find a suitable location for the RF control module. The location should be in a dry environment that is within reach of the LED light Bar Wiring Harness.
3. Connect the provided wiring harness to the LED Light bar Wiring harness as outlined in **Figure 1**.

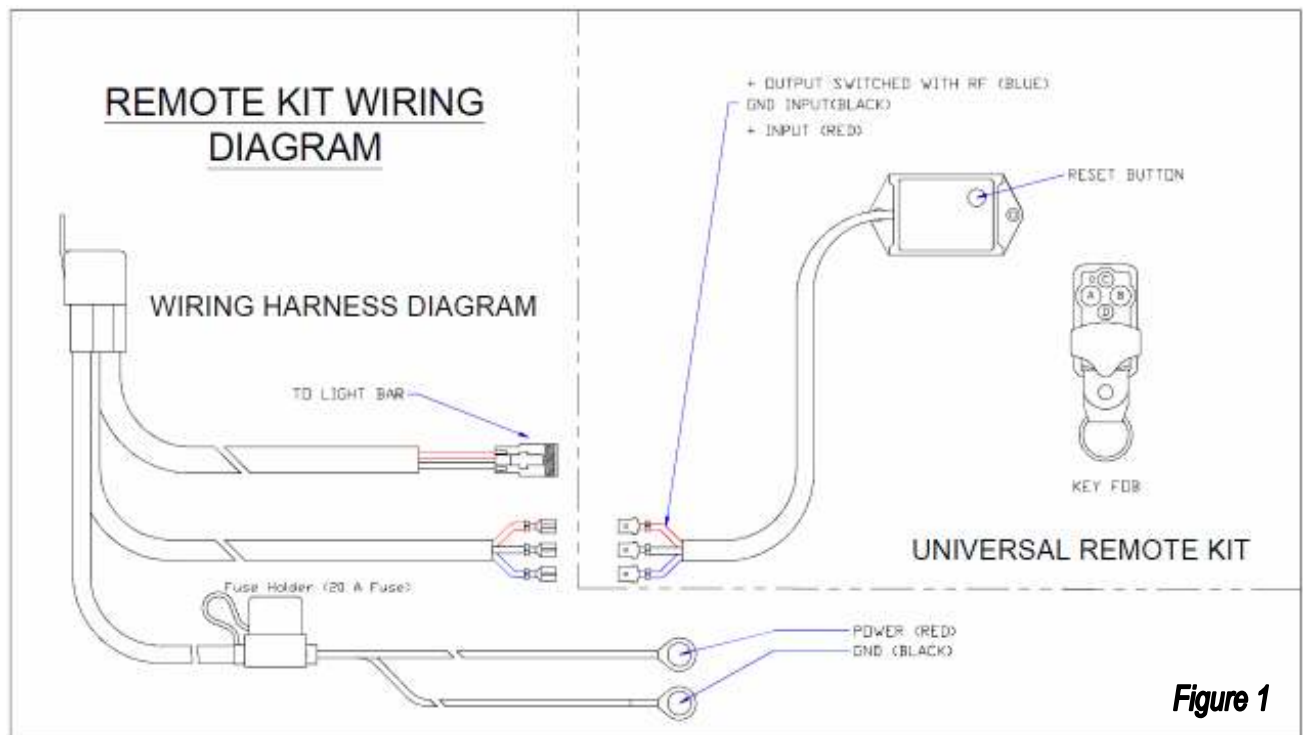

Figure 1

LIMITED 1 YEAR WARRANTY

Putco guarantees its Stainless Steel and Aluminum products against defects in workmanship and material for as long as you own your vehicle. All painted products have a 90 day warranty on the painted surface. Any defects resulting from faulty material or workmanship will be warranted by Putco and repaired or replaced at our discretion. Putco assumes no extra labor costs. Damages caused by freight carriers, improper installation, misuse, collision, or neglect will not be warranted by Putco.

PUTCO

4. Connect the three wires from the universal remote harness to the same color wire on the LED light bar wiring harness. (Note: If connections are loose, use pliers to crimp the connectors.)
5. Test that the desired location gets good signal from the key fob when outside the vehicle.
6. Mount the RF control module with 2 sided foam tape, zip ties, or screws through the mounting tabs to secure it to the vehicle.

Programming:

Note: Key Fob comes pre programmed from factory. Use this sequence only if key Fob was lost and replaced, or additional key Fobs are added.

1. Press and hold the reset button on the control module and the "A" button on the key fob for 5 seconds or until the connected light bar flickers. Refer to **Figure 2**

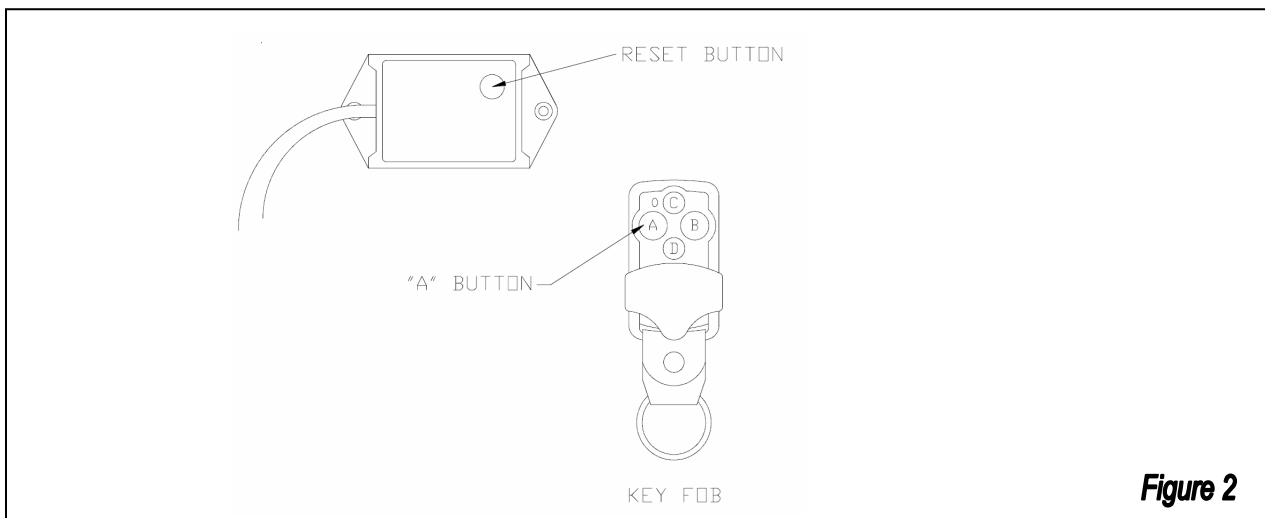

Usage Instructions:

1. Key fob usage and how to access 9 flash patterns are as follows:
 - Key A: Turn ON/OFF
 - Key B: Flash Forward (Key A needs to be "ON")
 - Key C: Flash Backward (Key A needs to be "ON")
 - Key D: SOS Exclusive mode.

Troubleshooting:

1. Indicator light will not turn on – Check electrical connections to the RF module/Check fuse in light bar harness.
2. Key Fob will not turn on light bar- Check that key Fob has been properly programmed/check that module is not getting outside interference. Replace battery (Part number 27A)

LIMITED 1 YEAR WARRANTY

Putco guarantees its Stainless Steel and Aluminum products against defects in workmanship and material for as long as you own your vehicle. All painted products have a 90 day warranty on the painted surface. Any defects resulting from faulty material or workmanship will be warranted by Putco and repaired or replaced at our discretion. Putco assumes no extra labor costs. Damages caused by freight carriers, improper installation, misuse, collision, or neglect will not be warranted by Putco.